

More information:
www.blug.es/eng/productos/

BLUG[®]
 Credeblug, s.l.



MACHINE TYPE
CLAMSHELL GRAB
WORKING SYSTEM
ELECTRO-HYDRAULIC
MATERIAL TO BE HANDLED

REFERENCE

C2-1,8

p. 24

RELATED PRODUCTS

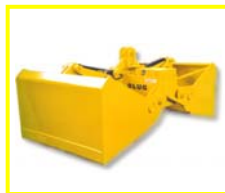

C2H-1,8



C2A-2,8



CM4-1,8

MAXIMUM MATERIAL DENSITY

1,8 T/M³

CYLINDER QUANTITY

2

PILED AND BULK MATERIAL UP TO 1,8 t/m³ DENSITY

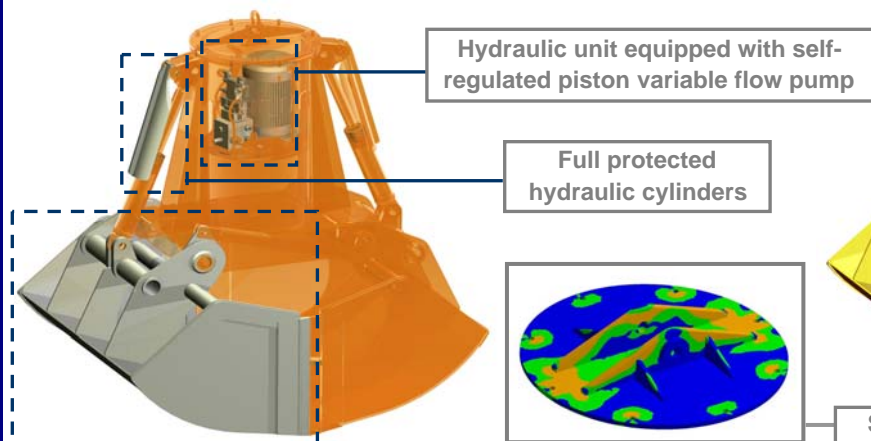

Structure validated by Finite Elements Analysis

Clamshell design with optimal penetration that allows full loading in all the operations thanks to a kinematic design at lifting and penetration mode including wear resistant lips

EQUIPMENT NEEDED

- Hook(s) or lifting chain(s).
- Electric connection for hydraulic unit.

TECHNICAL INFORMATION

- Robust structure in S355 J2G3 rolled steel.
- Oil tank tightly enclosed and protected from environment impurities.
- Reduced height, multi-stable, can work at any angle ($\pm 60^\circ$).
- Design & fabrication according to standard FEM 1001/98 section I.
- CE conformity.

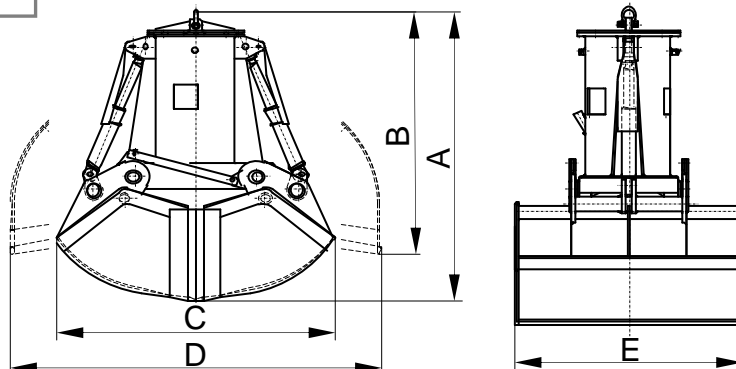

Reference	Capacity m ³	Engine 40% ED kW	Intensity 400 V A	Working pressure bar	Closing time s	Opening time s	Crane SWL t	Weight kg	Dimensions mm				
									A	B	C	D	E
C2-1000-1,8	1	7,3	14,5	120	8	4	4	1430	2080	1820	1750	2230	1250
C2-1250-1,8	1,25	7,3	14,5	150	9	5	4	1500	2170	1835	1850	2410	1300
C2-1500-1,8	1,5	7,3	14,5	175	10	5	5	1560	2230	1845	1950	2525	1400
C2-2000-1,8	2	10	20	160	13	7	6,3	2330	2430	2100	2150	2800	1600
C2-2500-1,8	2,5	10	20	190	13	7	8	2450	2530	2120	2250	2995	1700
C2-3000-1,8	3	20,5	39	150	13	7	10	3230	2930	2510	2450	3220	1800
C2-3500-1,8	3,5	20,5	39	170	13	7	10	3360	2990	2520	2550	3335	1900

SUBJECT TO CHANGE WITHOUT NOTICE.

You can request any model's offer visiting our web site www.blug.es or sending an email to comercial@blug.es