

More information:
www.blug.es/eng/productos/

BLUG[®]
 Credeblug, s.l.



REFERENCE
C2-2,8



p. 28

MACHINE TYPE
CLAMSHELL GRAB

MAXIMUM MATERIAL DENSITY
2,8 T/M³

WORKING SYSTEM
ELECTRO-HYDRAULIC

CYLINDER QUANTITY
2

MATERIAL TO BE HANDLED
PILED AND BULK MATERIAL UP TO 2,8 t/m³ DENSITY

RELATED PRODUCTS



C2H-2,8



C2A-2,8



CM4-2,8

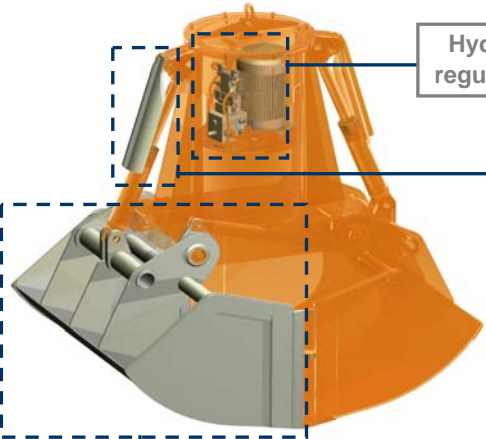

Hydraulic unit equipped with self-regulated piston variable flow pump

Full protected hydraulic cylinders

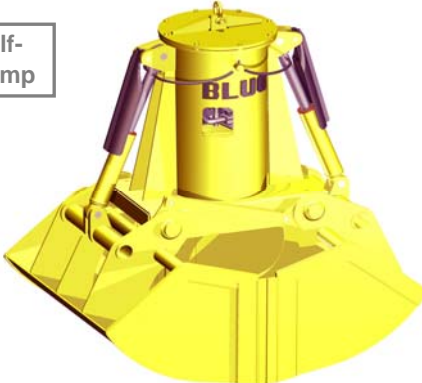
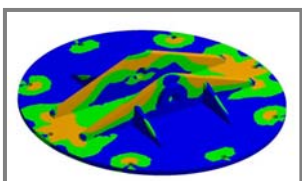

Structure validated by Finite Elements Analysis

Clamshell design with optimal penetration that allows full loading in all the operations thanks to a kinematic design at lifting and penetration mode including wear resistant lips

EQUIPMENT NEEDED

- Hook(s) or lifting chain(s).
- Electric connection for hydraulic unit.

TECHNICAL INFORMATION

- Robust structure in S355 J2G3 rolled steel.
- Oil tank tightly enclosed and protected from environment impurities.
- Reduced height, multi-stable, can work at any angle ($\pm 60^\circ$).
- Design & fabrication according to standard FEM 1001/98 section I.
- CE conformity.

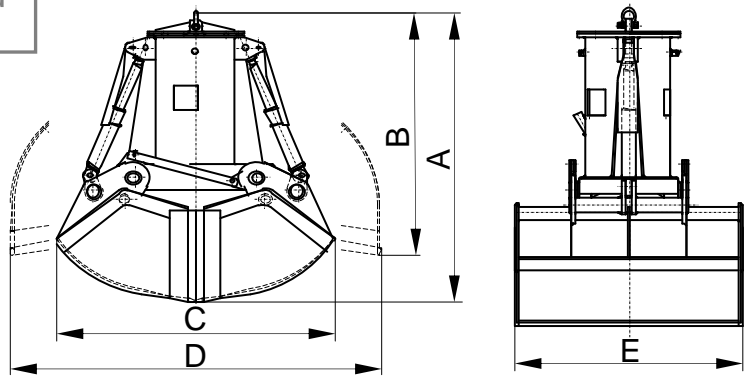

Reference	Capacity m ³	Engine 40% ED kW	Intensity 400 V A	Working pressure bar	Closing time s	Opening time s	Crane SWL t	Weight kg	Dimensions mm				
									A	B	C	D	E
C2-500-2,8	0,5	7,3	14,5	110	7	4	3,2	1330	1900	1790	1650	1880	1020
C2-750-2,8	0,75	10	20	150	7	4	4	1470	2000	1805	1800	2080	1100
C2-1000-2,8	1	10	20	200	8	4	5	1570	2080	1820	1950	2225	1170
C2-1250-2,8	1,25	10	20	150	11	8	6,3	2220	2280	2075	2050	2505	1280
C2-1500-2,8	1,5	10	20	180	11	8	8	2370	2340	2085	2100	2625	1380
C2-2000-2,8	2	20,5	39	150	11	8	10	3080	2800	2485	2300	2965	1470
C2-2500-2,8	2,5	25,5	48,5	190	11	8	12	3230	2880	2500	2400	3120	1600
C2-3000-2,8	3	25,5	48,5	220	11	8	12	3380	2950	2510	2500	3260	1730

SUBJECT TO CHANGE WITHOUT NOTICE.

You can request any model's offer visiting our web site www.blug.es or sending an email to comercial@blug.es