

More information:
www.blug.es/eng/productos/

BLUG[®]
 Credeblug, s.l.

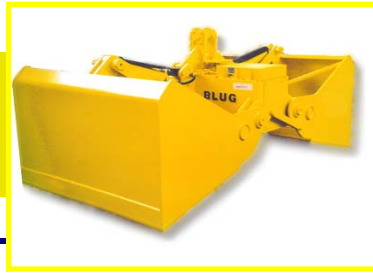

REFERENCE
C2H-1,8

p. 25

MACHINE TYPE
CLAMSHELL GRAB

MAXIMUM MATERIAL DENSITY
1,8 T/M³

WORKING SYSTEM
ELECTRO-HYDRAULIC
 MATERIAL TO BE HANDLED

TYPE
LOW HEIGHT



C2-1,8



CV2-1,8



CM4-1,8

PILED AND BULK MATERIAL UP TO 1,8 t/m³ DENSITY

Hydraulic unit in horizontal position to reduce grab's height and equipped with self-regulated piston variable flow pump

Full protected hydraulic cylinders

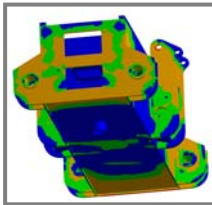

Structure validated by Finite Elements Analysis

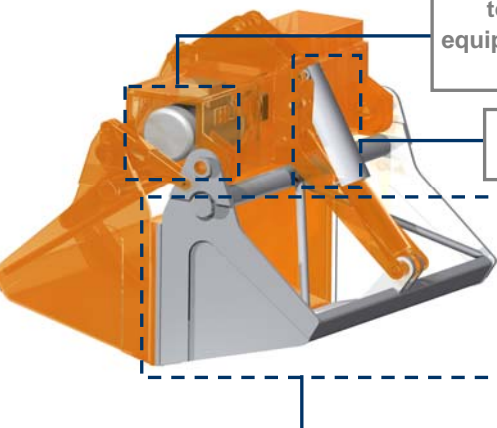

Clamshell design with optimal penetration that allows full loading in all the operations thanks to a kinematic design at lifting and penetration mode including wear resistant lips

EQUIPMENT NEEDED

- Hook(s) or lifting chain(s).
- Electric connection for hydraulic unit.

TECHNICAL INFORMATION

- Robust structure in S355 J2G3 rolled steel.
- Oil tank tightly enclosed and protected from environment impurities.
- Reduced height, multi-stable, can work at any angle ($\pm 60^\circ$).
- Design & fabrication according to standard FEM 1001/98 section I.
- CE conformity.

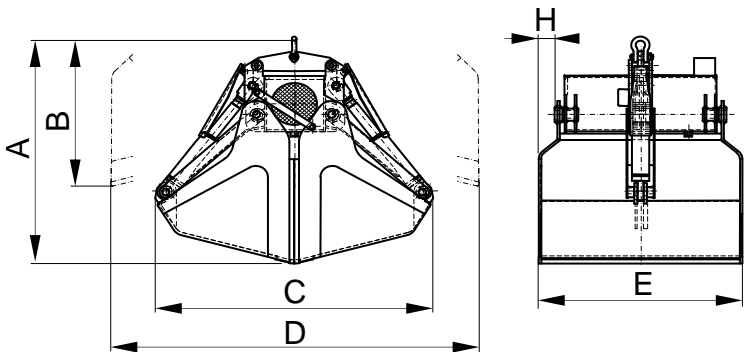

Reference	Capacity	Engine	Intensity	Working	Closing	Opening	Crane	Weight	Dimensions					
	m ³	40% ED	400 V	pressure	time	time			mm	A	B	C	D	E
		kW	A	bar	s	s	t	kg	A	B	C	D	E	H
C2H-1250-1,8	1,25	7,3	14,5	150	10	5	4	1520	1565	1065	1820	2735	1660	100
C2H-1500-1,8	1,5	10	20	200	10	5	6	1550	1630	1040	1840	2540	1700	120
C2H-2000-1,8	2	10	20	170	14	7	6	2420	1890	1275	2300	2880	1810	0
C2H-2500-1,8	2,5	14,5	28	220	14	7	8	2520	1920	1285	2370	2935	1800	0
C2H-3000-1,8	3	14,5	28	180	13	7	10	3010	2070	1360	2585	3200	1900	0
C2H-3500-1,8	3,5	20,5	39	220	13	7	12	3160	2070	1360	2585	3200	2255	180
C2H-4500-1,8	4,5	20,5	39	170	13	7	14	4175	2365	1485	2960	3720	1990	0
C2H-5000-1,8	5	25,5	48,5	180	13	7	16	4290	2325	1475	2910	3640	2500	255
C2H-5500-1,8	5,5	25,5	48,5	210	13	7	16	4450	2325	1475	2910	3640	2600	305

SUBJECT TO CHANGE WITHOUT NOTICE.

You can request any model's offer visiting our web site www.blug.es or sending an email to comercial@blug.es