

More information:

www.blug.es/eng/productos/

BLUG[®]

Credeblug, s.l.

MACHINE TYPE
CLAMSHELL GRAB

WORKING SYSTEM

MECHANICAL

MATERIAL TO BE HANDLED

FERTILIZER, PILED AND BULK MATERIAL UP TO 0,8 t/m³ DENSITY

Pulleys block with tempered contact surfaces and mounted on cushions / rollings

Articulated arms to compensate misalignment between valves and top body

Structure validated by Finite Elements Analysis

Clamshell design with optimal penetration that allows full loading in all the operations thanks to a kinematic design at lifting and penetration mode including wear resistant lips

EQUIPMENT NEEDED

- 2 lifting cables.
- 2 opening / closing cables.

TECHNICAL INFORMATION

- Robust structure in S355 J2G3 rolled steel.
- Complete load through maximum penetration force.
- Design & fabrication according to standard FEM 1001/98 section I.
- CE conformity.

REFERENCE

CM4-0,8



MAXIMUM MATERIAL DENSITY

0,8 T/M³

CABLE QUANTITY

4

RELATED PRODUCTS



CM4G-0,8



CM4-1,1



CM4G-1,1

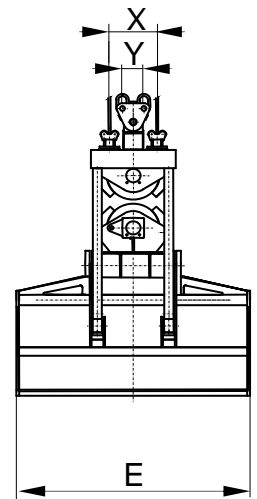
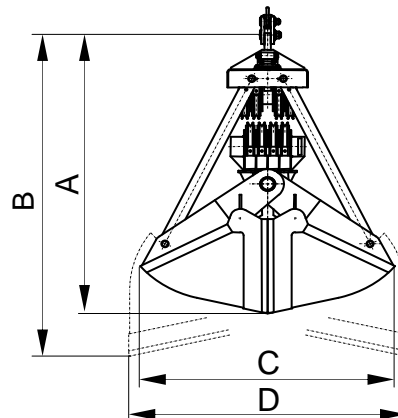

Reference	Capacity 30° slope m ³	Withdrawn cable m	Pulley Ø mm	Cable Ø mm	Crane SWL t	Weight kg	Dimensions mm						
							A	B	C	D	E	X	Y
CM4-3250-0,8	3,25	3	355	16	5	1800	2830	3210	2400	2640	2050	380	160
CM4-4250-0,8	4,25	3	355	16	6,3	2500	2830	3210	2400	2640	2680	380	160
CM4-5500-0,8	5,5	3,6	450	22	8	3100	3540	3710	2745	3560	2260	480	220
CM4-7500-0,8	7,5	3,6	450	22	10	3500	3540	3710	2745	3560	3050	480	220
CM4-9000-0,8	9	7,8	560	26	12,5	5200	3865	4325	3155	3770	2780	595	280
CM4-12000-0,8	12	7,8	560	26	16	6400	3865	4325	3155	3770	3520	595	280
CM4-14000-0,8	14	8,9	630	32	20	8600	4755	5190	3940	5180	3100	670	350
CM4-18500-0,8	18,5	8,9	630	32	25	9500	4805	5190	4030	5275	3920	670	350
CM4-20000-0,8	20	8,9	630	32	32	10600	4805	5190	4030	5275	4250	670	350
CM4-25000-0,8	25	9,1	710	36	40	12200	5200	5320	4300	5480	3960	755	380

SUBJET TO CHANGE WITHOUT NOTICE.

Reeving system 1:3 / 1:4

You can request any model's offer visiting our web site www.blug.es or sending an email to comercial@blug.es