

More information:
www.blug.es/eng/productos/

BLUG[®]
 Credeblug, s.l.

MACHINE TYPE
CLAMSHELL GRAB
WORKING SYSTEM
MECHANICAL

MATERIAL TO BE HANDLED

FERTILIZER, CEREALS, COAL, PILED AND BULK MATERIAL UP TO 1,1 t/m³ DENSITY

Pulleys block with tempered contact surfaces and mounted on cushions / rollings

Articulated arms to compensate misalignment between valves and top body

Structure validated by Finite Elements Analysis

Clamshell design with optimal penetration that allows full loading in all the operations thanks to a kinematic design at lifting and penetration mode including wear resistant lips

EQUIPMENT NEEDED

- 2 lifting cables.
- 2 opening / closing cables.

TECHNICAL INFORMATION

- Robust structure in S355 J2G3 rolled steel.
- Complete load through maximum penetration force.
- Design & fabrication according to standard FEM 1001/98 section I.
- CE conformity.

REFERENCE
CM4-1,1



MAXIMUM MATERIAL DENSITY
1,1 T/M³
CABLE QUANTITY
4

p. 38

RELATED PRODUCTS



CM4G-1,1



CM4-0,8



CM4G-0,8

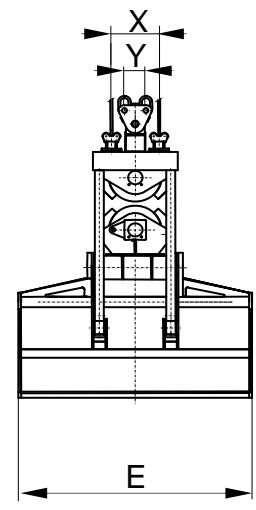
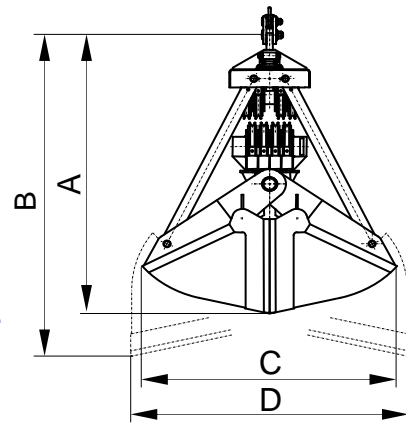

Reference	Capacity 35° slope m ³	Withdrawn cable m	Pulley Ø mm	Cable Ø mm	Crane SWL t	Weight kg	Dimensions mm						
							A	B	C	D	E	X	Y
CM4-2500-1,1	2,5	4,1	355	16	5	1900	2775	3085	2085	2300	1950	380	160
CM4-3500-1,1	3,5	4,1	355	16	8	2600	2830	3210	2400	2640	1960	380	160
CM4-4500-1,1	4,5	4,8	450	22	10	3200	3540	3710	2745	3560	2035	480	220
CM4-5500-1,1	5,5	4,8	450	22	10	3600	3640	3725	2920	3755	2135	480	220
CM4-7000-1,1	7	7,8	560	26	12,5	4800	3865	4325	3155	3770	2155	595	280
CM4-9000-1,1	9	7,8	560	26	16	6000	3965	4345	3320	3965	2455	595	280
CM4-11000-1,1	11	7,8	560	26	20	7000	4065	4370	3495	4160	2705	595	280
CM4-14500-1,1	14,5	8,9	630	32	25	8600	4705	5165	3735	5095	3055	670	350
CM4-18000-1,1	18	8,9	630	32	32	10100	4805	5190	4030	5275	3505	670	350
CM4-23000-1,1	23	9,1	710	36	40	12900	5200	5320	4300	5480	3650	755	380

SUBJET TO CHANGE WITHOUT NOTICE.

Reeving system 1:4

You can request any model's offer visiting our web site www.blug.es or sending an email to comercial@blug.es