

More information:  
[www.blug.es/eng/productos/](http://www.blug.es/eng/productos/)

**BLUG**<sup>®</sup>  
 Credeblug, s.l.

**MACHINE TYPE**  
**CLAMSHELL GRAB**  
**WORKING SYSTEM**  
**MECHANICAL**

**MATERIAL TO BE HANDLED**

**CEMENT, CLINKER, PILED AND BULK MATERIAL UP TO 1,8 t/m<sup>3</sup> DENSITY**

Pulleys block with tempered contact surfaces and mounted on cushions / rollings

Articulated arms to compensate misalignment between valves and top body

Structure validated by Finite Elements Analysis

Clamshell design with optimal penetration that allows full loading in all the operations thanks to a kinematic design at lifting and penetration mode including wear resistant lips

**EQUIPMENT NEEDED**

- 2 lifting cables.
- 2 opening / closing cables.

**TECHNICAL INFORMATION**

- Robust structure in S355 J2G3 rolled steel.
- Complete load through maximum penetration force.
- Design & fabrication according to standard FEM 1001/98 section I.
- CE conformity.

**REFERENCE**  
**CM4-1,8**



**MAXIMUM MATERIAL DENSITY**  
**1,8 T/M<sup>3</sup>**

**CABLE QUANTITY**  
**4**

p. 40

**RELATED PRODUCTS**



**CM4-1,1**



**CM4-2,8**



**CM2-1,8**

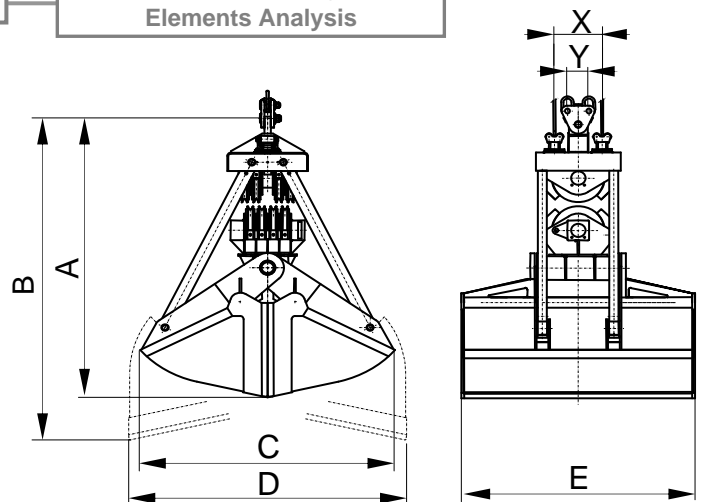
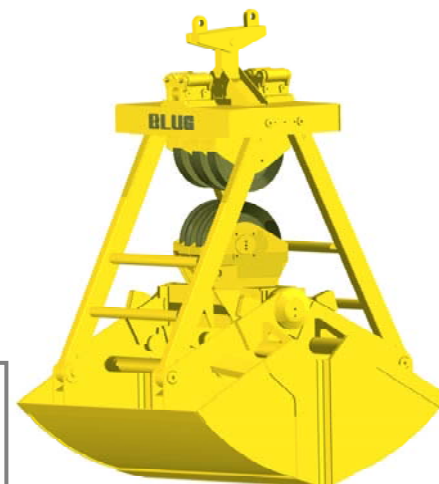

Reference	Capacity 30° slope m <sup>3</sup>	Withdrawn cable m	Pulley Ø mm	Cable Ø mm	Crane SWL t	Weight kg	Dimensions mm						
							A	B	C	D	E	X	Y
CM4-1600-1,8	1,6	4,1	355	16	6,3	1900	2525	2765	1895	2130	1660	380	160
CM4-2000-1,8	2	4,1	355	16	6,3	2200	2625	2795	2065	2320	1760	380	160
CM4-2500-1,8	2,5	4,9	450	22	8	2900	3040	3325	2240	2510	1885	480	220
CM4-3000-1,8	3	4,9	450	22	10	3200	3140	3350	2410	2700	1935	480	220
CM4-4000-1,8	4	8,8	560	26	12,5	4700	3575	4055	2685	3200	2005	595	280
CM4-5000-1,8	5	8,8	560	26	16	5200	3675	4080	2840	3400	2105	595	280
CM4-6000-1,8	6	8,8	560	26	20	6500	3775	4100	3005	3590	2255	595	280
CM4-8000-1,8	8	11,1	630	32	25	8200	4215	4840	3370	4030	2355	670	350
CM4-10000-1,8	10	11,1	630	32	32	9800	4315	4865	3545	4225	2805	670	350
CM4-12500-1,8	12,5	11,3	710	36	40	12500	4750	5140	3860	4520	2890	755	380

SUBJET TO CHANGE WITHOUT NOTICE.

Reeving system 1:4 / 1:5

You can request any model's offer visiting our web site [www.blug.es](http://www.blug.es) or sending an email to [comercial@blug.es](mailto:comercial@blug.es)