

More information:

www.blug.es/eng/productos/

BLUG

Credeblug, s.l.

MACHINE TYPE

ORANGE PEEL GRAB

WORKING SYSTEM

ELECTRO-HYDRAULIC

MATERIAL TO BE HANDLED

MIXED SCRAP, BALED SCRAP WOOD, FRAG SCRAP, INDUSTRIAL REFUSE, MISCELLANEOUS SCRAP, SCRAP 1-2...



REFERENCE

P-1,8

p. 3

RELATED PRODUCTS



PR8-1,8



P-3N



PM4-1,8

MAXIMUM MATERIAL DENSITY

1,8 T/M³

STRUCTURE

ROUND

Hydraulic unit equipped with self-regulated piston variable flow pump

Complete load through maximum penetration force applied with special profile jaws designed for the product

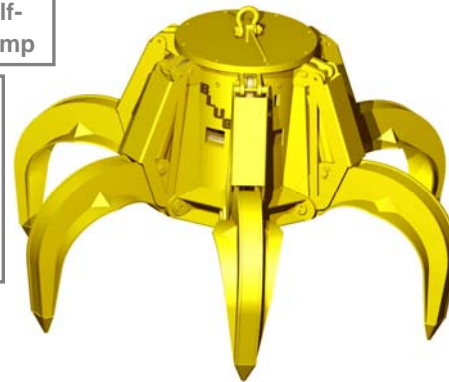

Structure validated by Finite Elements Analysis

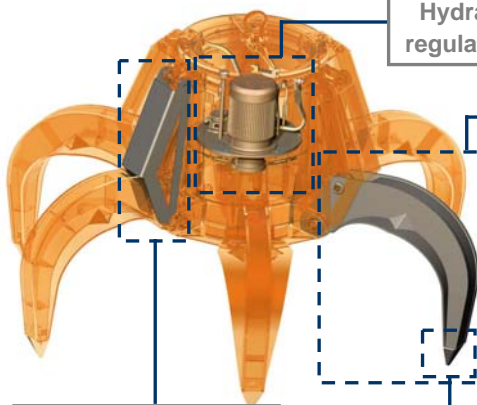

Full protected hydraulic cylinders

Special penetration teeth built in wear resistant manganese steel

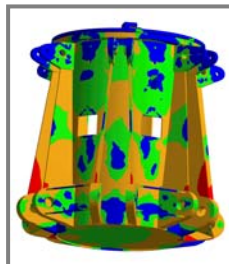

EQUIPMENT NEEDED

- Hook(s) or lifting chain(s).
- Electric connection for hydraulic unit.

TECHNICAL INFORMATION

- Robust structure in S355 J2G3 rolled steel.
- Oil tank tightly enclosed and protected from environment impurities.
- Reduced height, multi-stable, can work at any angle ($\pm 60^\circ$).
- Design & fabrication according to standard FEM 1001/98 section I.
- CE conformity.

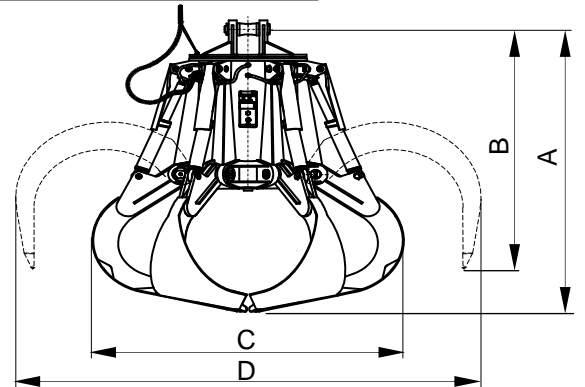

Reference	Capacity m ³	Jaw quantity	Engine 40% ED kW	Intensity 400 V A	Working pressure bar	Closing time (1) s	Opening time s	Crane SWL t	Weight kg	Dimensions mm			
										A	B	C	D
P5-500-1,8	0,5	5	7,3	14,5	140	8	5	2,5	1050	1640	1480	1310	1810
P5-750-1,8	0,75	5	7,3	14,5	160	8	5	2,5	1150	1730	1520	1470	1980
P5-1000-1,8	1	5	10	20	165	8	5	4	1560	2100	1820	1850	2705
P5-1250-1,8	1,25	5	10	20	190	8	5	4	1650	2200	1850	1950	2900
P6-1600-1,8	1,6	6	14,5	28	135	9	5	6,3	2620	2410	2110	2260	3070
P6-2000-1,8	2	6	20,5	39	175	9	6	6,3	2710	2510	2145	2375	3270
P6-2500-1,8	2,5	6	20,5	39	175	9	7	8	2810	2660	2195	2475	3550
P6-3200-1,8	3,2	6	25,5	48,5	170	12	8	10	3940	2985	2480	2615	3895
P6-4000-1,8	4	6	25,5	48,5	175	12	9	12,5	4250	3135	2535	2805	4190
P6-5000-1,8	5	6	40	74,5	160	14	9	18	7100	3375	3020	3090	4480
P7-6300-1,8	6,3	7	51	94	190	16	10	20	7890	3575	3115	3245	4845
P7-8000-1,8	8	7	51	94	200	16	11	25	8320	3775	3205	3470	5220
P7-10000-1,8	10	7	62,5	117	185	16	12	30	9600	4160	3485	3805	5870
P7-12000-1,8	12	7	70	129	205	22	13	35	12200	4710	3960	4070	6090

SUBJET TO CHANGE WITHOUT NOTICE.

(1) THE LOAD APREHENSION TIME IS CONSIDERED AT 85% OF THE SHELLS STROKE.

You can request any model's offer visiting our web site www.blug.es or sending an email to comercial@blug.es