

More information:  
[www.blug.es/eng/productos/](http://www.blug.es/eng/productos/)

**BLUG**<sup>®</sup>  
 Credeblug, s.l.

**MACHINE TYPE**  
**ORANGE PEEL GRAB**  
**WORKING SYSTEM**  
**HYDRAULIC**  
**MATERIAL TO BE HANDLED**



**REFERENCE**  
**PNA-0,7**

p. 8

**RELATED PRODUCTS**



**PNA-1,8**



**P-0,7**

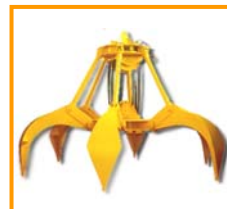

**PM4-0,7**

**MAXIMUM MATERIAL DENSITY**  
**0,7 T/M<sup>3</sup>**  
**STRUCTURE**  
**ROUND**

**RUBBISH, URBAN SOLID WASTE, TURNINGS DOMESTIC AND LIGHT INDUSTRIAL REFUSES, CUT TIRES...**

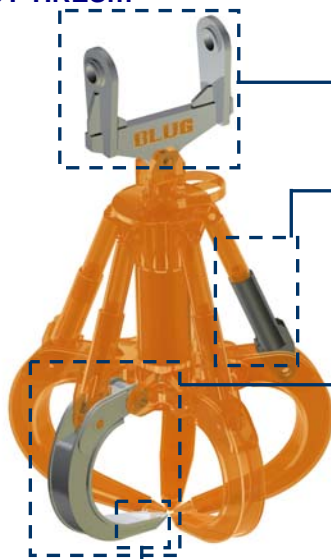

Adapted lifting rock-level for each application and forklift truck / mobile crane with optional rotation device

Full protected hydraulic cylinders

Complete load through maximum penetration force applied with special profile jaws designed for the product

Special interchangeable penetration teeth built in wear resistant manganese steel

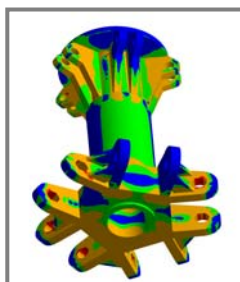

Structure validated by Finite Elements Analysis

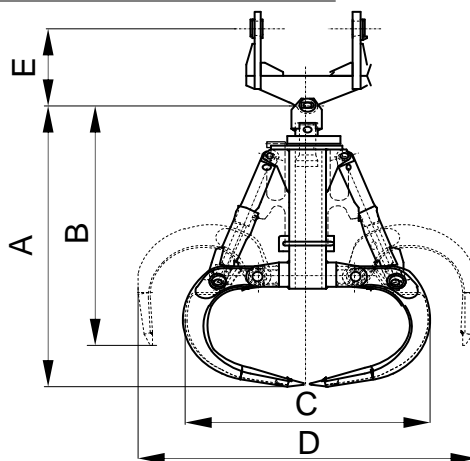

**EQUIPMENT NEEDED**

- Attachment from forklift truck / mobile crane.
- Hydraulic supply from external system.

**TECHNICAL INFORMATION**

- Robust structure in S355 J2G3 rolled steel.
- Mechanical (120°) or hydraulic (360°) rotation device.
- Reduced height, multi-stable, can work at any angle (± 60°).
- Design & fabrication according to standard FEM 1001/98 section I.
- CE conformity.

Reference	Capacity m <sup>3</sup>	Jaw quantity	Working pressure bar	Crane SWL t	Weight kg	Dimensions mm				
						A	B	C	D	E
PNA-800-0,7	0,8	5	250	1,6	870	1865	1520	1715	2260	Depending on forklift truck / mobile crane's suspension
PNA-1000-0,7	1	5	250	1,6	930	1940	1530	1830	2430	
PNA-1250-0,7	1,25	5	250	2,5	1200	2035	1550	1990	2630	
PNA-1500-0,7	1,5	5	250	2,5	1470	2145	1580	2110	2865	
PNA-2000-0,7	2	5	250	3,2	1560	2260	1600	2270	3110	
PNA-2500-0,7	2,5	5	250	4	1790	2430	1630	2450	3380	
PNA-3000-0,7	3	6	250	5	2560	2540	1675	2650	3690	
PNA-3500-0,7	3,5	6	250	6,3	2900	2740	2030	2760	3740	
PNA-4000-0,7	4	6	250	6,3	3180	2840	2060	2060	3950	

SUBJECT TO CHANGE WITHOUT NOTICE.

You can request any model's offer visiting our web site [www.blug.es](http://www.blug.es) or sending an email to [comercial@blug.es](mailto:comercial@blug.es)