

More information:

www.blug.es/eng/productos/

BLUG[®]
Credeblug, s.l.

REFERENCE

PNA-1,8

p. 9



RELATED PRODUCTS



PNA-3



P-1,8



PM4-1,8

MACHINE TYPE
ORANGE PEEL GRAB
WORKING SYSTEM
HYDRAULIC

MAXIMUM MATERIAL DENSITY

1,8 T/M³

STRUCTURE

ROUND

MATERIAL TO BE HANDLED

MIXED SCRAP, BALED SCRAP WOOD, INDUSTRIAL REFUSE, MISCELLANEOUS SCRAP, SCRAP 1-2 HANDLING...

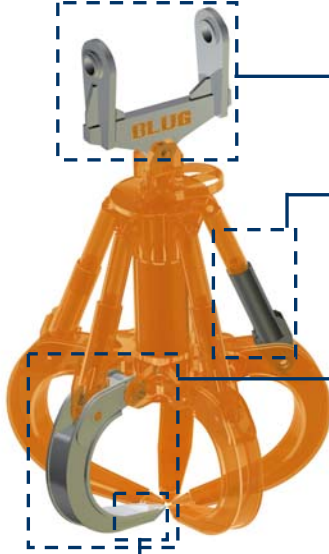

Adapted lifting rock-level for each application and forklift truck / mobile crane with optional rotation device

Full protected hydraulic cylinders

Complete load through maximum penetration force applied with special profile jaws designed for the product

Special interchangeable penetration teeth built in wear resistant manganese steel

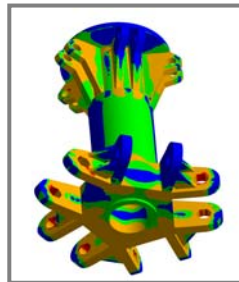

Structure validated by Finite Elements Analysis



EQUIPMENT NEEDED

- Attachment from forklift truck / mobile crane.
- Hydraulic supply from external system.

TECHNICAL INFORMATION

- Robust structure in S355 J2G3 rolled steel.
- Mechanical (120°) or hydraulic (360°) rotation device.
- Reduced height, multi-stable, can work at any angle (± 60°).
- Design & fabrication according to standard FEM 1001/98 section I.
- CE conformity.

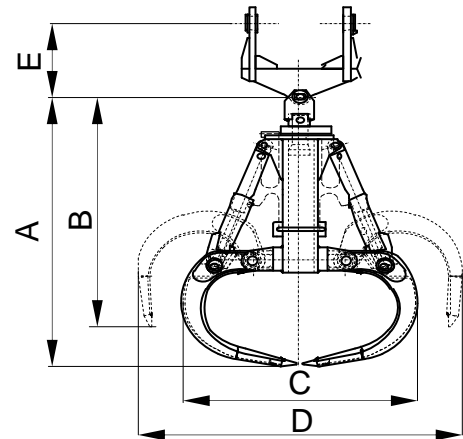

Reference	Capacity m ³	Jaw quantity	Working pressure bar	Crane SWL t	Weight kg	Dimensions mm				
						A	B	C	D	E
PNA-330-1,8	0,33	5	250	1,6	950	1655	1550	1310	1645	Depending on forklift truck / mobile crane's suspension
PNA-400-1,8	0,4	5	250	2,5	970	1705	1555	1380	1755	
PNA-500-1,8	0,5	5	250	2,5	1020	1775	1575	1475	1890	
PNA-630-1,8	0,63	5	250	2,5	1050	1815	1915	1555	2020	
PNA-800-1,8	0,8	5	250	3,2	1460	1950	1620	1830	2290	
PNA-1000-1,8	1	5	250	4	1605	2015	1610	1870	2400	
PNA-1250-1,8	1,25	6	250	5	2045	2250	1840	1985	2520	
PNA-1500-1,8	1,5	6	250	6,3	2470	2345	1900	2110	2700	
PNA-2000-1,8	2	6	250	8	3155	2445	1920	2280	2910	
PNA-2500-1,8	2,5	6	250	10	3710	2580	1960	2385	3160	

SUBJECT TO CHANGE WITHOUT NOTICE.

You can request any model's offer visiting our web site www.blug.es or sending an email to comercial@blug.es