

More information:

www.blug.es/eng/productos/

BLUG[®]

Credeblug, s.l.

REFERENCE

PNA-3

p. 10



RELATED PRODUCTS



PNA-1,8



P-3N



PM4-3

MACHINE TYPE
ORANGE PEEL GRAB

MAXIMUM MATERIAL DENSITY

3 T/M³

WORKING SYSTEM

HYDRAULIC

STRUCTURE

ROUND

MATERIAL TO BE HANDLED

ALL TYPE OF SCRAP, STONES, TRUCKS, BRIQUETTES, PIG-IRON...



Adapted lifting rock-level for each application and forklift truck / mobile crane with optional rotation device

Full protected hydraulic cylinders

Complete load through maximum penetration force applied with special profile jaws designed for the product



Structure validated by Finite Elements Analysis

Special interchangeable penetration teeth built in wear resistant manganese steel

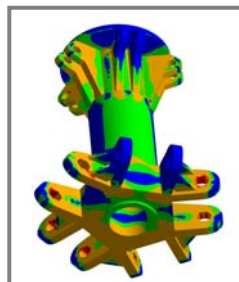

EQUIPMENT NEEDED

- Attachment from forklift truck / mobile crane.
- Hydraulic supply from external system.

TECHNICAL INFORMATION

- Robust structure in S355 J2G3 rolled steel.
- Mechanical (120°) or hydraulic (360°) rotation device.
- Reduced height, multi-stable, can work at any angle ($\pm 60^\circ$).
- Design & fabrication according to standard FEM 1001/98 section I.
- CE conformity.

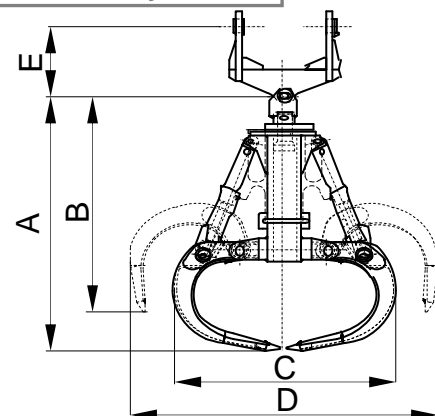

Reference	Capacity	Jaw quantity	Working pressure	Crane SWL	Weight	Dimensions				
						mm				
	m ³		bar	t	kg	A	B	C	D	E
PNA-250-3	0,25	5	250	1,6	680	1280	1100	1225	1640	Depending on forklift truck / mobile crane's suspension
PNA-400-3	0,4	5	250	2,5	950	1460	1230	1400	1870	
PNA-500-3	0,5	5	250	3,2	1250	1640	1385	1575	2105	
PNA-750-3	0,75	5	250	4	1550	1825	1538	1750	2340	
PNA-1000-3	1	5	250	6,3	2300	2015	1695	1900	2550	
PNA-1250-3	1,25	6	250	8	2750	2300	2060	1940	3120	
PNA-1500-3	1,5	6	250	8	3100	2550	2295	2100	3300	
PNA-1750-3	1,75	6	250	10	3500	2800	2500	2200	3450	
PNA-2000-3	2	6	250	10	3800	3000	2685	2280	3620	
PNA-2500-3	2,5	6	250	12,5	4500	3200	2890	2400	3800	
PNA-3000-3	3	6	250	16	5600	3300	2910	2450	3880	

SUBJECT TO CHANGE WITHOUT NOTICE.

You can request any model's offer visiting our web site www.blug.es or sending an email to comercial@blug.es