

More information:  
[www.blug.es/eng/productos/](http://www.blug.es/eng/productos/)

**BLUG**<sup>®</sup>  
 Credeblug, s.l.



REFERENCE

**PR8-3**

p. 6

RELATED PRODUCTS



**PR8-1,8**



**P-3N**



**PM4-3**

**MACHINE TYPE**  
**ORANGE PEEL GRAB**  
**WORKING SYSTEM**  
**ELECTRO-HYDRAULIC**  
**MATERIAL TO BE HANDLED**

**CORE SCRAP, PIG-IRON, PELLETS, OA SCRAP, PELLETS, FERRO ALLOYS, INDUSTRIAL HEAVY WASTES, SMALL PACKAGES OF SCRAP...**

**MAXIMUM MATERIAL DENSITY**

**3 T/M<sup>3</sup>**

**STRUCTURE**  
**RECTANGULAR**

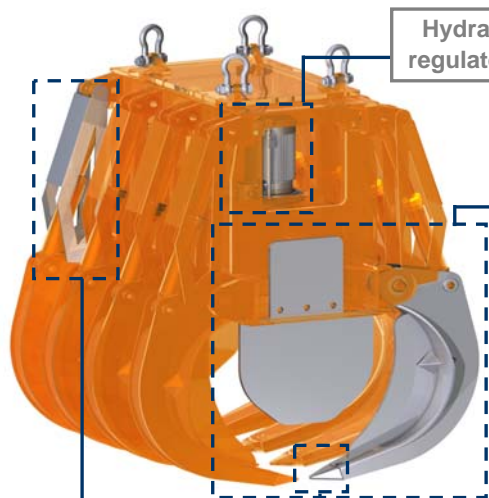

Hydraulic unit equipped with self-regulated piston variable flow pump

Complete load through maximum penetration force applied with special profile jaws designed for the product with side closing plates

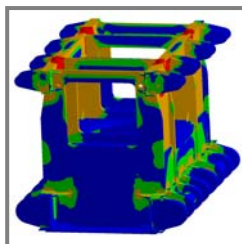

Structure validated by Finite Elements Analysis

Full protected hydraulic cylinders

Special penetration teeth built in wear resistant manganese steel

**EQUIPMENT NEEDED**

- Hook(s) or lifting chain(s).
- Electric connection for hydraulic unit.

**TECHNICAL INFORMATION**

- Robust structure in S355 J2G3 rolled steel.
- Oil tank tightly enclosed and protected from environment impurities.
- Reduced height, multi-stable, can work at any angle ( $\pm 60^\circ$ ).
- Design & fabrication according to standard FEM 1001/98 section I.
- CE conformity.

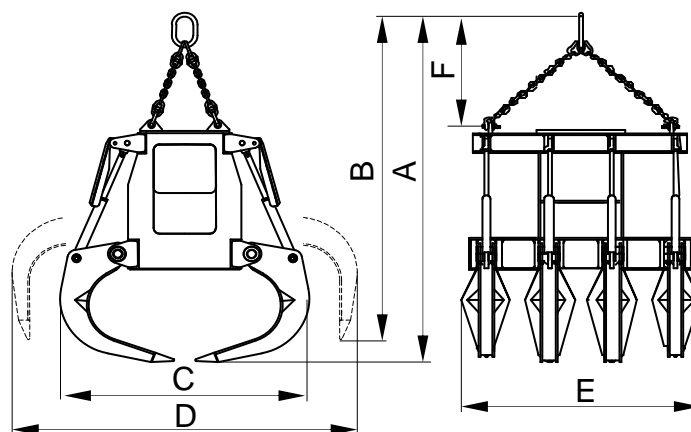

Reference	Capacity m <sup>3</sup>	Engine 40% ED kW	Intensity 400 V A	Working pressure bar	Closing time (1) s	Opening time s	Crane SWL t	Weight kg	Dimensions mm					
									A	B	C	D	E	F
PR8-1000-3	1	20,5	39	130	10	6	8	4300	2820	2720	1620	2510	2000	800
PR8-1500-3	1,5	25,5	48,5	125	12	7	10	5500	3450	2320	1940	2760	2000	900
PR8-2000-3	2	31,5	61	160	12	7	12,5	6400	3600	2370	2050	3050	2000	900
PR8-2500-3	2,5	51	94	130	13	8	16	8500	3900	3660	2050	3250	2300	1200
PR8-3000-3	3	62,5	117	160	13	8	20	9300	4000	3720	2180	3440	2300	1200

SUBJET TO CHANGE WITHOUT NOTICE.

(1) THE LOAD APREHENSION TIME IS CONSIDERED AT 85% OF THE SHELLS STROKE.

You can request any model's offer visiting our web site [www.blug.es](http://www.blug.es) or sending an email to [comercial@blug.es](mailto:comercial@blug.es)